

WWW.ACHILDGUIDETO.COM

KEY STAGE TWO REVISION PACK

Test Revision for End of Key Stage Two SATs



Scale and Number lines 3

Negative Numbers 8

Information from Tables 10

Co-ordinates 11

Reflection Transformations 12

Fractions 13

Translation 16

Rotation 17

Percentages 18

Money Problems 19

Distance Problems 20

Patterns 21

Area and Volume 22

Algebra 25

Number Operations with Decimal Fractions 26

Resources to cut out and stick in your books 27



SCALE AND NUMBER LINES

1.

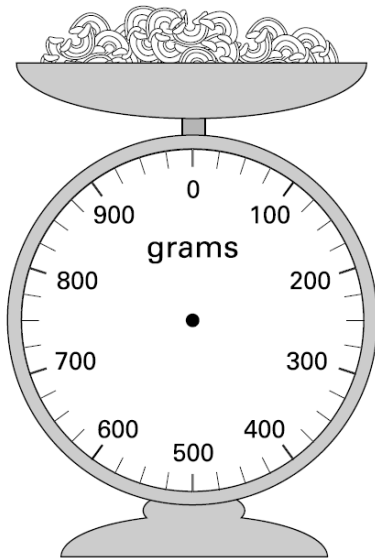

a. Mark the scale with an arrow showing the weight of the pasta to be 275g.

b. Jack adds another 350g. Mark the scale to show the new weight.

c. How many more grams would now be needed to make it so there was 1kg of pasta?

d. Through how many degrees does the pointer move if it moves from reading 200g to reading 300g?

e. In degrees, what is the difference between the two pointer marks that you have drawn onto the scale?

f. Jack puts 600g of flour on the scale. How many degrees is it from where the pointer would be pointing to 1kg on the scale?

2.

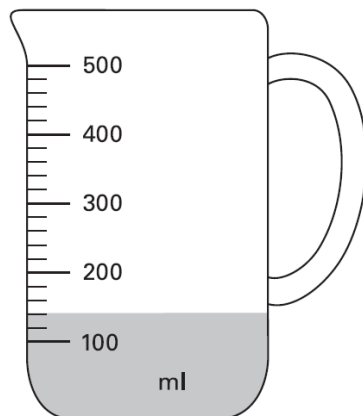

a. How much liquid is in the jug?

b. Tom wants the jug to contain 325ml. How much more liquid does he need to add to the jug?

c. Kath has an identical jug. She fills the jug so there is $\frac{1}{4}$ litre in the jug. How much more liquid is there in Kath's jug than the one shown?

d. Holly starts with a jug and she adds to it, 300ml and then pours out $\frac{1}{4}$ litre. How much liquid remains in Holly's jug?

e. Bill needs 400ml of water. He pours the water in but has 10% too much. Draw a line to show where the water comes to in Bill's jug.

3.

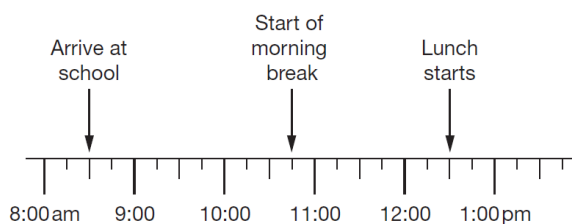

a. It takes Grace 35 minutes to walk to school. What is the latest she can set off and be on time?

b. Morning break lasts for 15 minutes. How long does the lesson between break and dinner time last?

c. Lunch lasts 45 minutes. What time does afternoon registration take place?



4.

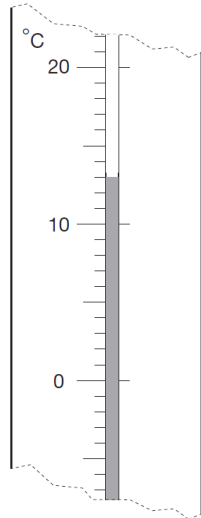

- a. What temperature does the thermometer read?
- b. The temperature has dropped from the daily high by 9°C. What was the temperature at the warmest part of the day?
- c. Overnight, the temperature continues to drop until it reaches -2.5°C. Mark this on the thermometer.
- d. How much lower is the lowest daily temperature (-2.5°C) than the temperature shown on the thermometer?
- e. How much must the temperature rise to reach half of the boiling point of water?
- f. The coldest day last year reached a temperature of -19°C. How much colder is this than the temperature shown on the thermometer?

5.

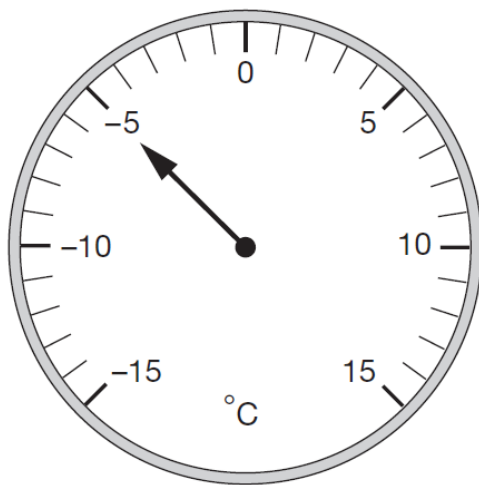

- a. A different thermometer is shown opposite. Where might you find a thermometer with this type of reading?
- b. The temperature drops by a further seven degrees. Mark on the new temperature.
- c. From -5°C, the temperature rises by seventeen degrees. What is the temperature now?
- d. How far must the temperature rise from -5°C to reach the boiling point of water?
- e. Do you think this thermometer would be used to measure the temperature of a classroom in our school? How do you know?

6.

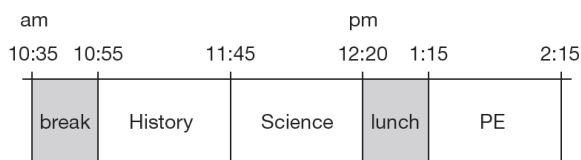

- a. For how long does the history lesson last?
- b. How much longer is PE. than science?
- c. How long do the children have for break and lunch altogether?
- d. What is the total time shown on this extract of the school timetable?



7

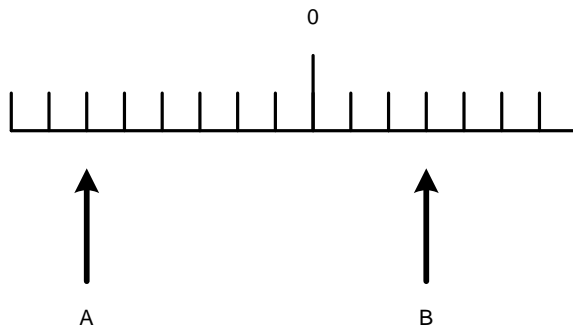

a. The numbers marked as A and B on the number line below are 90 apart. What is the value of A and B?

b. What are the values of $A + B =$

c. What would you get if performed the calculation

$$3B - A =$$

d. The value of B is 60. What is the new value of A?

e. The value of A is -30. What is the new value of B?

f. The value of B is 6. What is the new value of A?

8

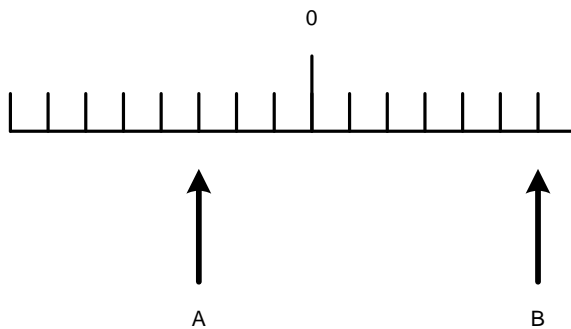

a. The difference between A and B is 18. What are the readings of A and B?

b. If B reads 18, what would A read?

c. If A reads -18, what would B read?

d. If the difference in readings between A and B is 99, what would A and B read?

e. If B read 0.6, what would the difference between A and B be?

f. If A read -0.6, what would the difference between A and B read?

9

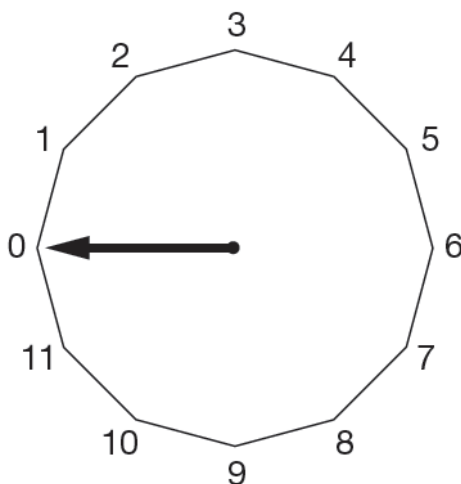

a. Ben rotated the pointer from zero through 150° . Where would the pointer be pointing now?

b. How many degrees is it from 4, moving clockwise round to 1?

c. How many degrees is it from 10, moving anti-clockwise, round to 6?

d. Jack starts the pointer at five. He rotates it round through 120° so he ends up at zero. In which direction has he rotated the pointer.

e. Ethan moves the pointer through 210° in a clockwise direction. He finishes up on 9. Where did he start?



10

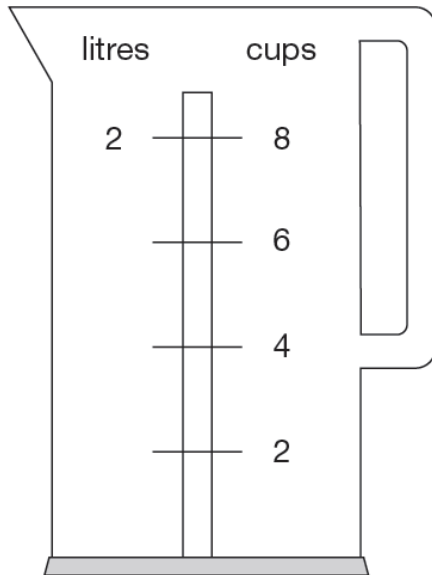

- How many millilitres are there in one cup?
- Emily makes a cup of tea for seven people. How many millilitres of water does she need?
- Mya starts with 1.5 litres in her kettle. She makes three cups of tea. How many millilitres are left in the kettle?
- Ethan puts just enough water in the kettle to make 3 cups of tea. How much water has he boiled?
- Harry likes a pot of tea. His pot holds $1\frac{1}{2}$ times as much as a normal mug. How much water does he need to fill his pot?
- Harry makes one and a half pots of tea. How much water does he need to do this?
- Harry fills the kettle. How many pots of tea can he make from one full kettle?

11

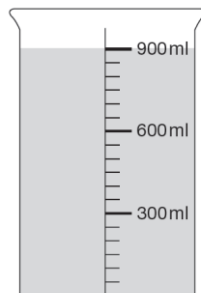

- Ellie pours out half the contents of the jug. Draw a line to show where the level of liquid reaches now.
- If Tom was to pour out two thirds of the liquid, how much liquid would there be left?
- Emily wants $\frac{3}{4}$ litre. How much liquid does she have to pour away?
- Jack pours away $\frac{1}{4}$ litre. How much liquid is left?

12

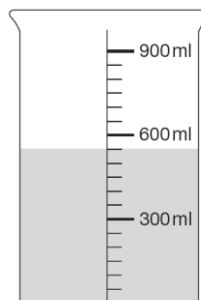

- How much liquid is in the jug now?
- How much less is it than was in the jug shown in Q11?
- How much more liquid would be needed to make a total of 1 litre?



13. Draw a line indicating where the level of the liquid should go in each case.

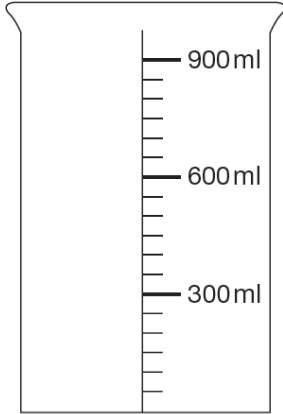

a. 200 ml

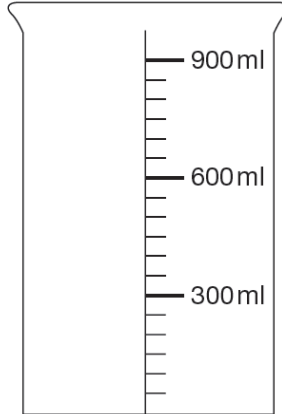

b. $\frac{1}{2}$ litre

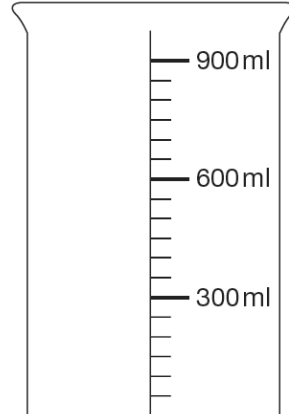

c. 350 ml

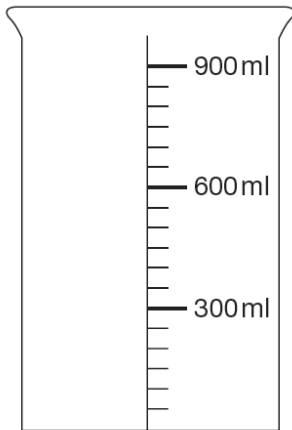

d. Half of 700ml

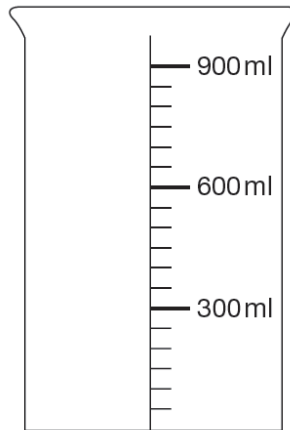

e. Double 400ml

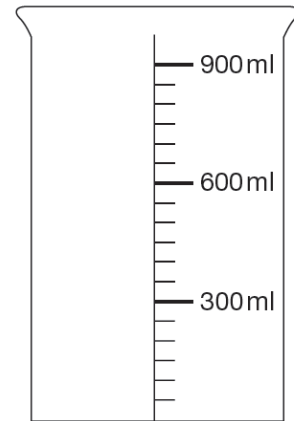

f. Treble 150ml

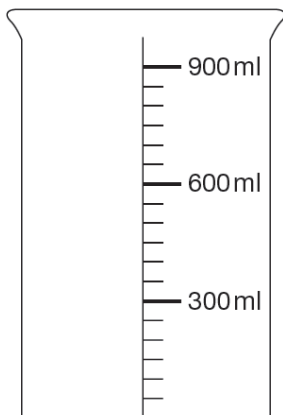

g. $\frac{3}{4}$ litre

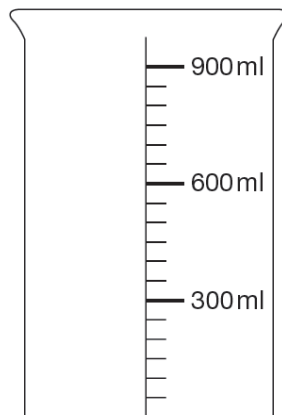

h. $\frac{1}{2}$ litre

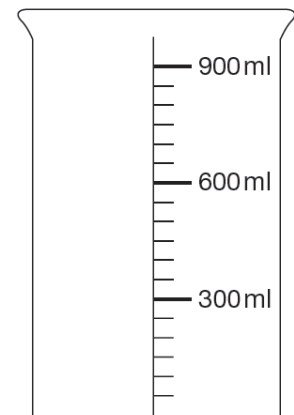

i. 475 ml



NEGATIVE NUMBERS

1

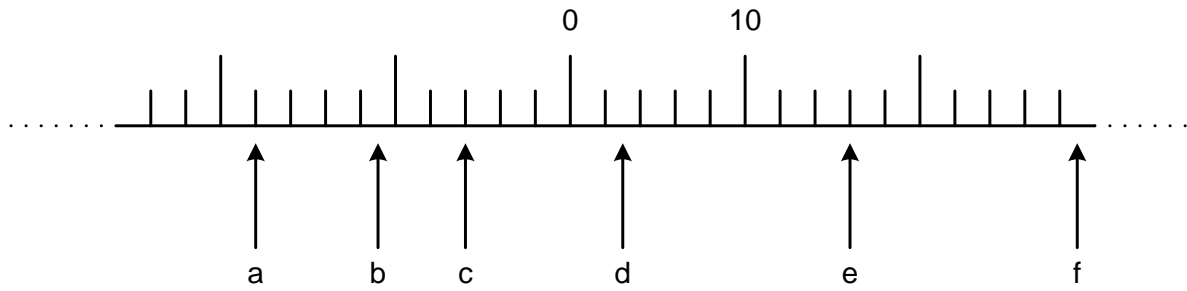

2

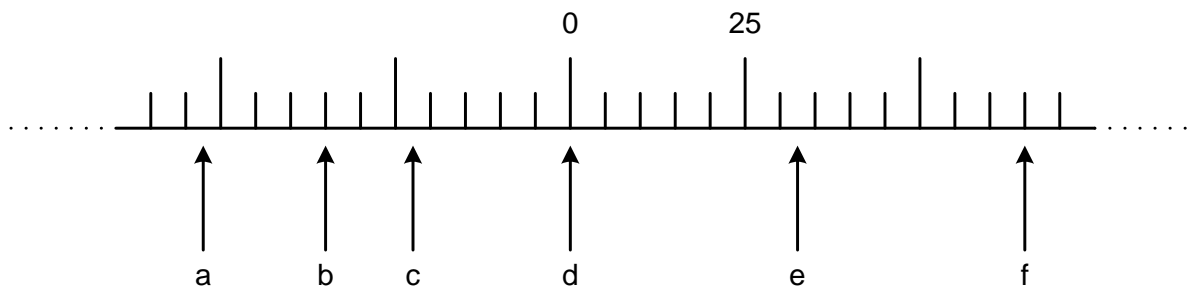

3

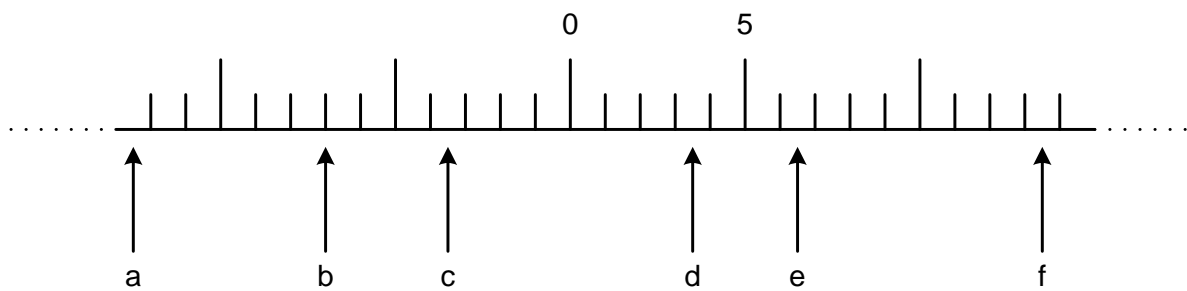



- | | | | | | | | | |
|-----|----|---------------|----|---------------|----|-----------------|----|---------------|
| 4. | a. | $17 - 24 =$ | b. | $19 - 82 =$ | c. | $27 - 80 =$ | d. | $28 - 183 =$ |
| 5. | a. | $157 - 204 =$ | b. | $191 - 842 =$ | c. | $227 - 480 =$ | d. | $248 - 683 =$ |
| 6. | a. | $147 - 624 =$ | b. | $119 - 582 =$ | c. | $2147 - 8042 =$ | d. | $20 - 83 =$ |
| 7. | a. | $127 - 242 =$ | b. | $119 - 385 =$ | c. | $227 - 810 =$ | d. | $228 - 621 =$ |
| 8. | a. | $171 - 224 =$ | b. | $194 - 82 =$ | c. | $27 - 74 =$ | d. | $128 - 281 =$ |
| 9. | a. | $17 - 38 =$ | b. | $97 - 812 =$ | c. | $217 - 80 =$ | d. | $28 - 1843 =$ |
| 10. | a. | $172 - 191 =$ | b. | $9 - 18 =$ | c. | $192 - 19 =$ | d. | $82 - 183 =$ |

11

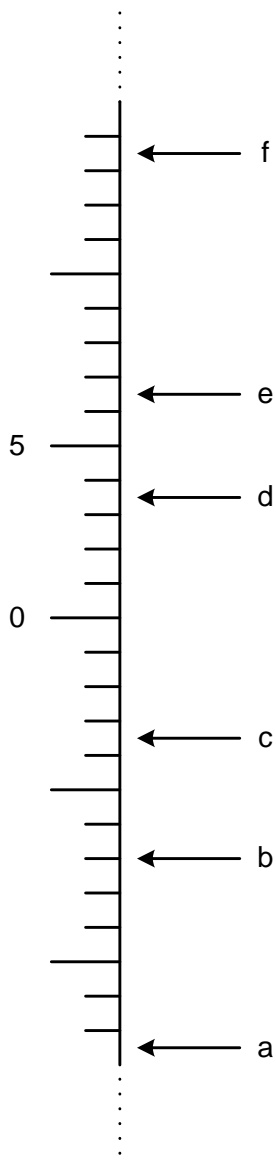

12

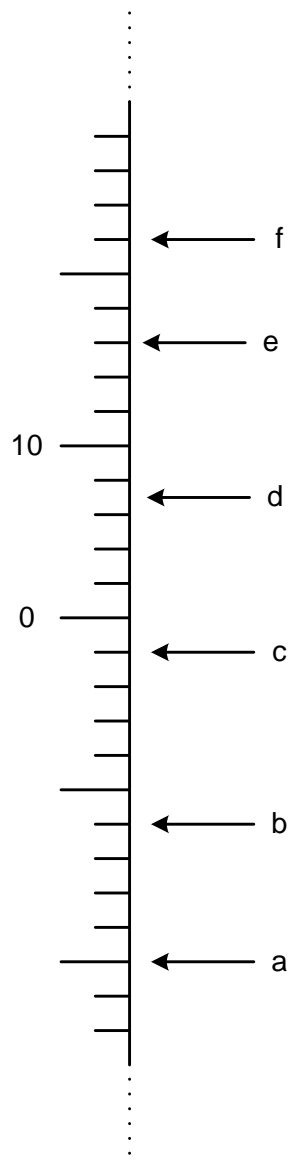

13

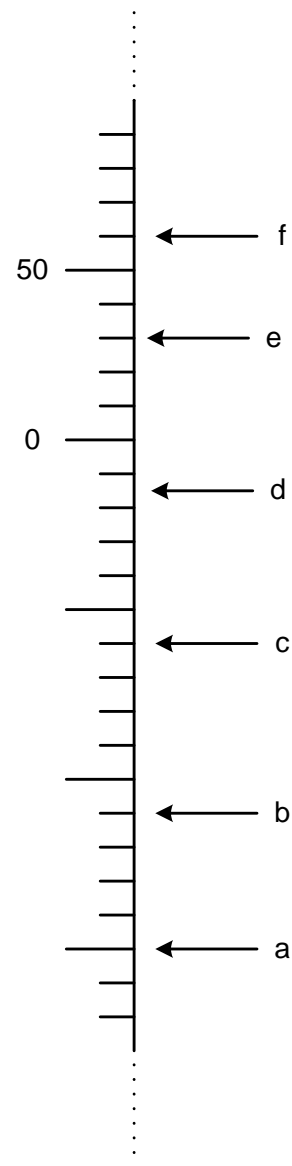



INFORMATION FROM TABLES

1

	number of journeys	money collected
Monday	23	£85
Tuesday	36	£112
Wednesday	18	£69
Thursday	31	£124
Friday	35	£109

a. What is the total number of journeys that the taxi driver made?

b. On what days did he make an odd number of journeys?

c. How much money did he collect altogether when he made an even number of journeys?

d. What is the mean average amount of money he made on Thursday?

e. What is the mean average amount of money he made overall?

2

	100m race	800m race
Elise	15.9 seconds	3 minutes 02 seconds
Jake	19.7 seconds	2 minutes 58 seconds
Teri	16.8 seconds	3 minutes 01 seconds
Neil	17.1 seconds	2 minutes 59 seconds
Barry	18.4 seconds	2 minutes 57 seconds

a. Who ran the median average race in the 100m event?

b. Who ran the median average race in the 800m event?

c. If the 800m event was a relay with five legs, each of 800m, how long would it take for the race to finish if these children were one team?

3

	Girls	Boys
zebra	9	3
lion	4	9
giraffe	7	4
monkey	8	7
elephant	6	5

a. Draw a bar chart showing how many children liked each type of animal.

b. If each child was only allowed one vote, what percentage of the children liked zebra best?

c. What percentage of the children liked elephants or monkeys best?

d. What percentage of girls liked lions best and what percentage of boys liked lions best?

e. What percentage of girls liked either giraffes or elephants best?



CO-ORDINATES

1 Write in the missing co-ordinates.

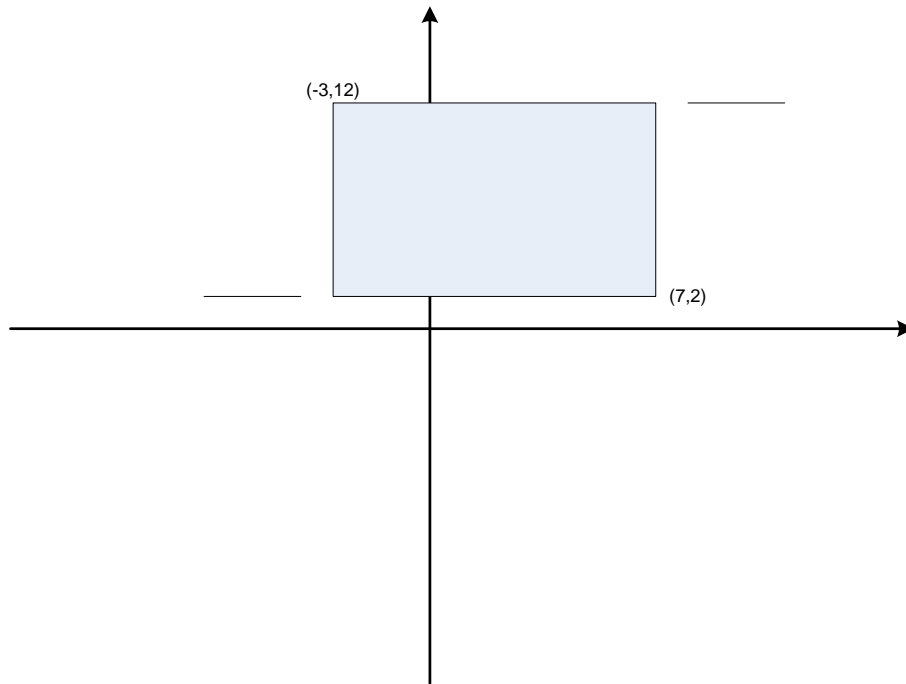

2

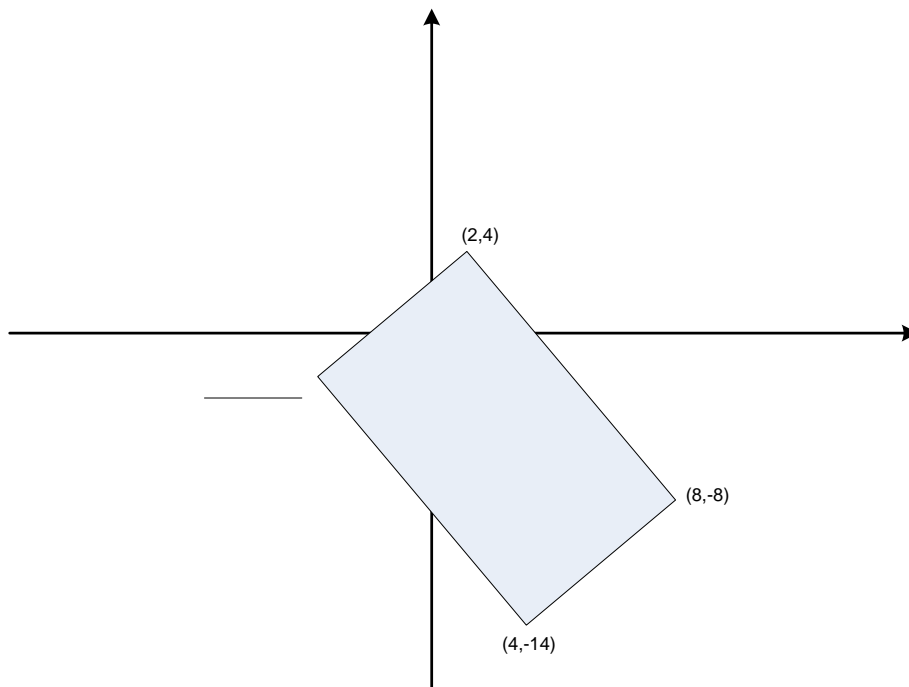



3 Below is a kite. Write in the missing co-ordinate.

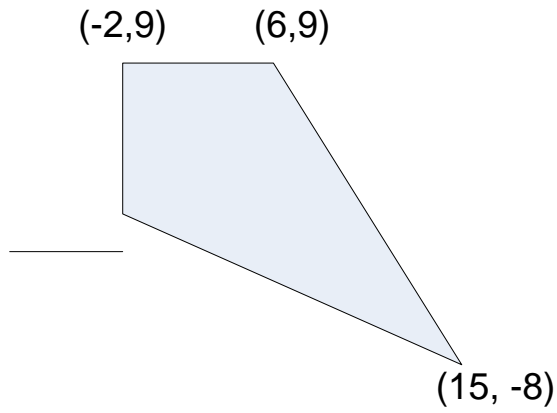

REFLECTION TRANSFORMATIONS

1.

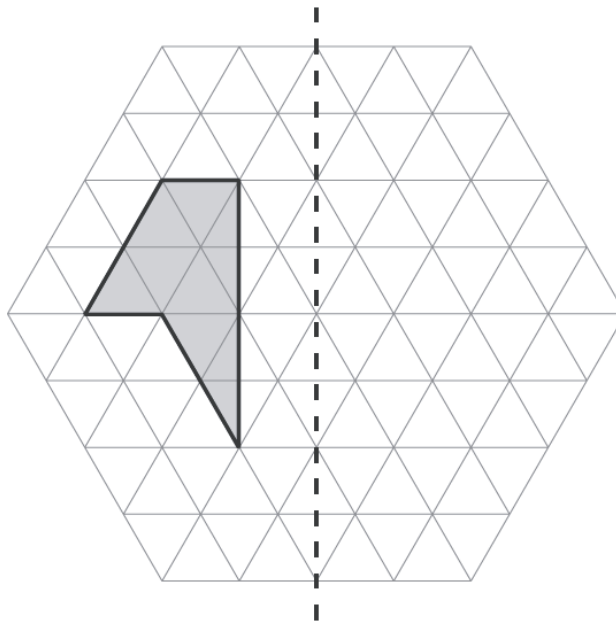

2. Mark on the lines of symmetry.

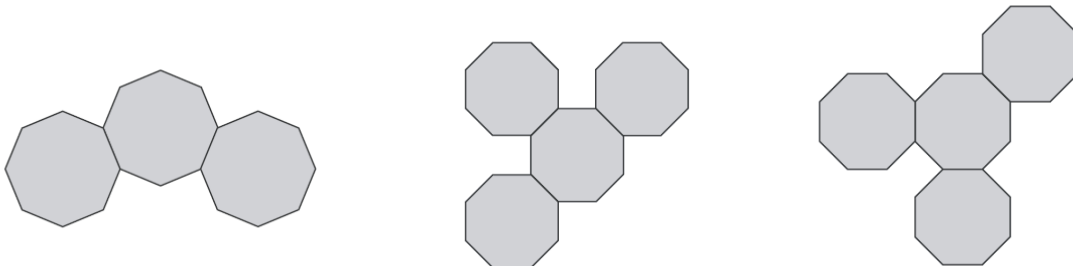



FRACTIONS

- 1 What fraction of the shape is shaded?

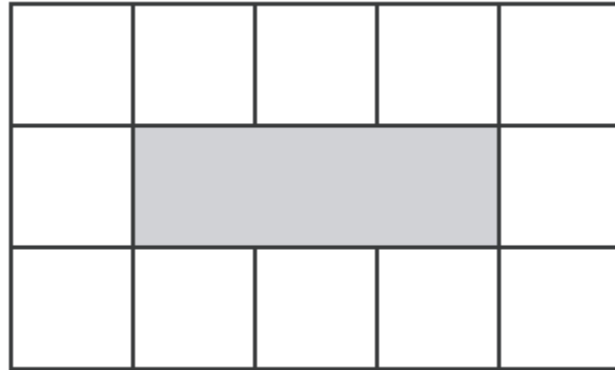

- 2

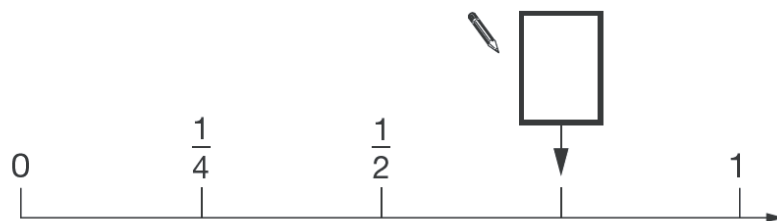

- 3 Put these masses into order starting with the lightest on the left.

2 kilograms	1 tonne	800 grams	$\frac{1}{2}$ kilogram
----------------	------------	--------------	---------------------------

- 4 How long is Holly's line in metres?

A 5p coin has a diameter of 1.8 centimetres.



Holly makes a straight line of 5p coins worth £10





- 5 Copy and shade one-fifth of this shape.

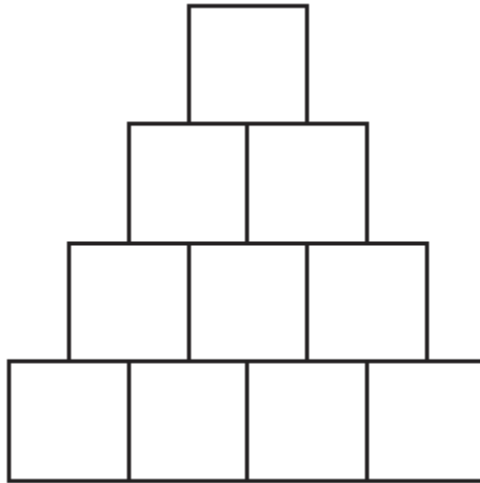

- 6 A square has a perimeter of 96cm. It is shown on the left below.

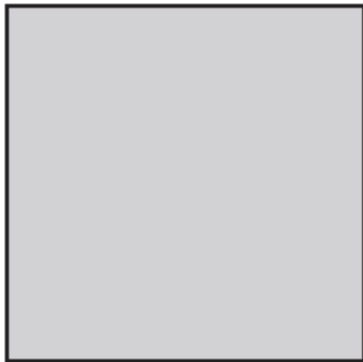

The square is cut in half as shown on the right.

- What is the perimeter of each oblong?
- What is the area of each oblong?
- Each oblong is cut horizontally in half to create four squares. What is the area of each of these squares?
- What is the perimeter of each of these squares?
- What is the perimeter of the squares as a proportion of the perimeter of the original square?



7. Here is a pattern on a grid.

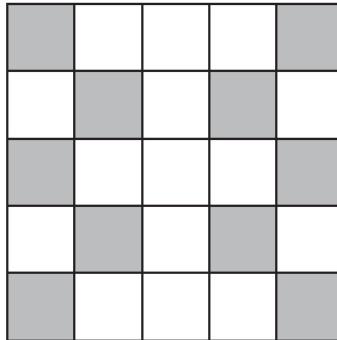

- a. What percentage of the grid is shaded?
- b. What fraction of the grid is shaded?
- c. What decimal fraction of the grid is shaded?
8. Here is a weighing scale with some flour on it.

Altogether, 2kg of flour are needed.

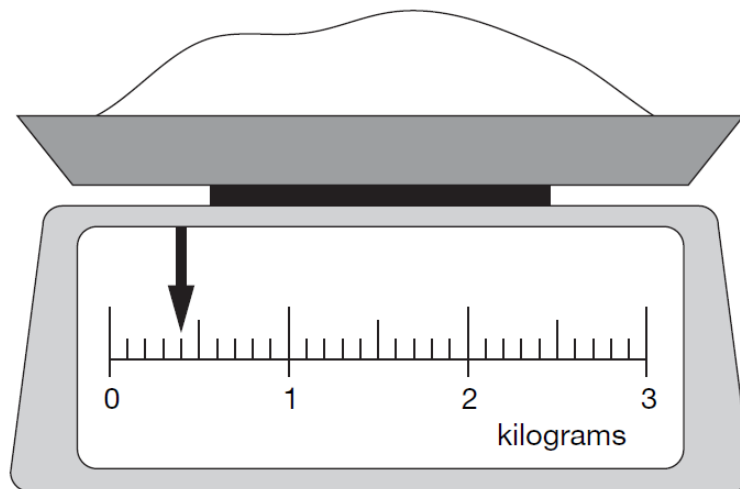

- a. What fraction of the flour is on the scale already?
- b. What fraction of the flour is still needed?
- c. What percentage of the flour is on the scale already?
- d. What percentage of the flour is still needed?
- e. What decimal fraction of the flour is on the scale already?
- f. What decimal fraction of the flour is still needed?

**TRANSLATION**

1. Point A moves to point B. Draw the shape in its new position.

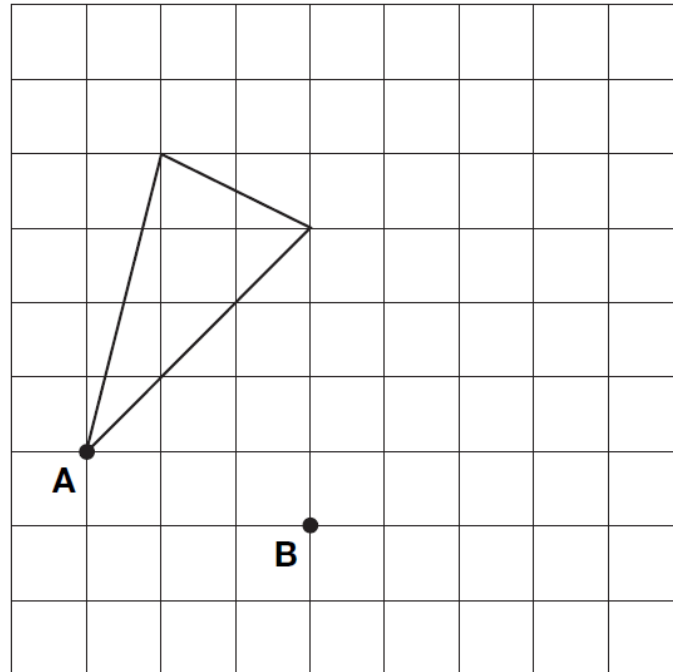

2. Point C moves so that $x=x+4$ and $y=y-2$. Draw the shape in its new position.

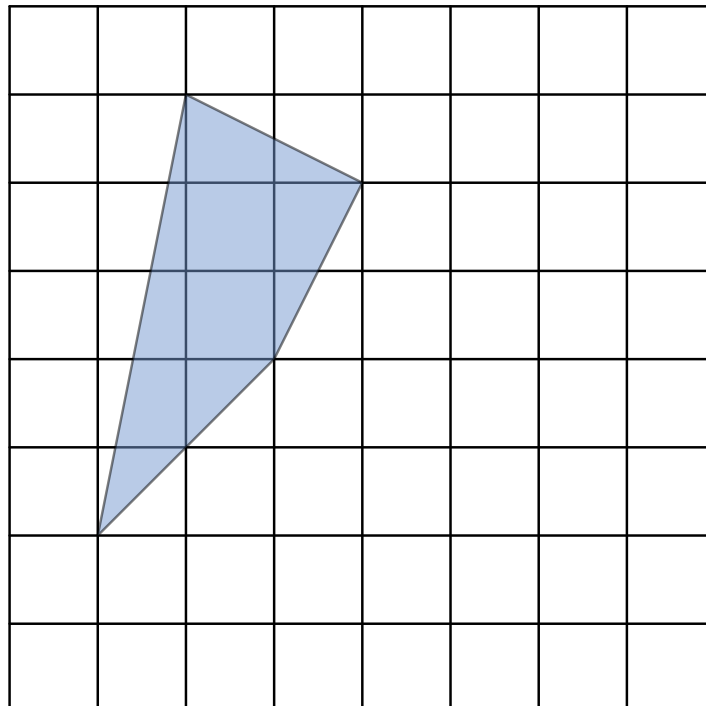



ROTATION

- 1 Rotate the shape half a turn clockwise about the cross in the middle.

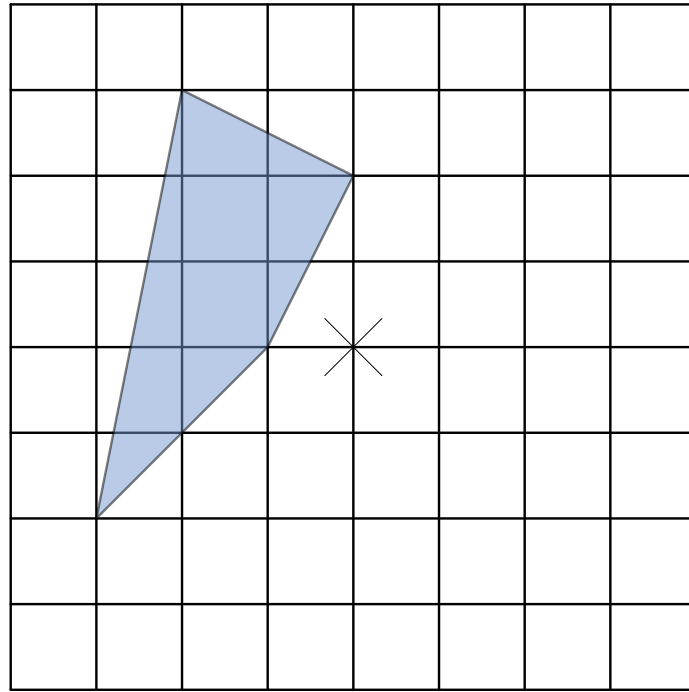

Rotate the shape a quarter turn counter-clockwise (anticlockwise).

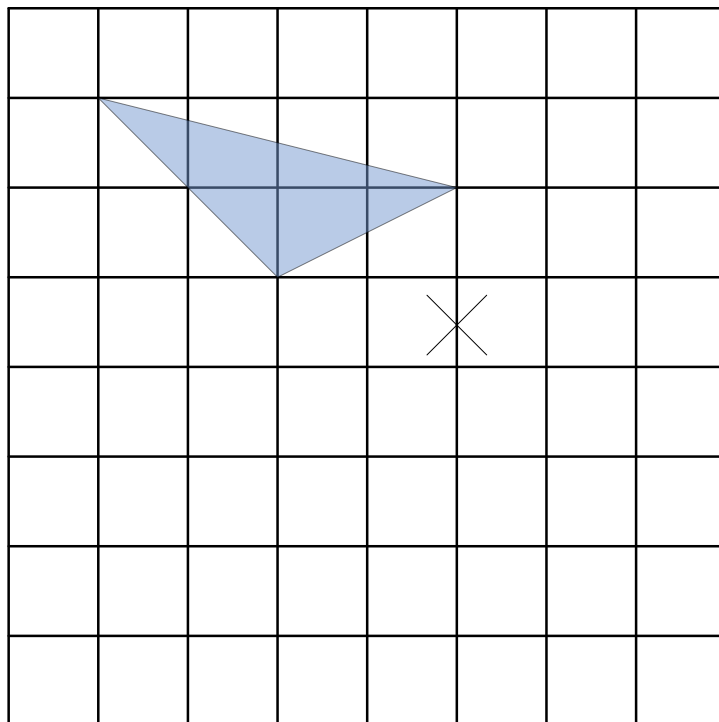



PERCENTAGES

1. Give 10% of the following numbers:
a. 30 b. 60 c. 90 d. 1920 e. 3820
f. 382 g. 827 h. 281 i. 3829 j. 81973
2. Increase the following numbers by 10%:
a. 30 b. 60 c. 90 d. 1920 e. 3820
f. 382 g. 827 h. 281 i. 3829 j. 81973
3. Decrease the following numbers by 10%:
a. 30 b. 60 c. 90 d. 1920 e. 3820
f. 382 g. 827 h. 281 i. 3829 j. 81973
4. Give 30% of the following numbers:
a. 30 b. 60 c. 90 d. 1920 e. 3820
f. 382 g. 827 h. 281 i. 3829 j. 81973
5. Increase the following numbers by 30%:
a. 30 b. 60 c. 90 d. 1920 e. 3820
f. 382 g. 827 h. 281 i. 3829 j. 81973
6. Decrease the following numbers by 30%:
a. 30 b. 60 c. 90 d. 1920 e. 3820
f. 382 g. 827 h. 281 i. 3829 j. 81973
7. Give 25% of the following numbers:
a. 30 b. 60 c. 90 d. 1920 e. 3820
f. 382 g. 827 h. 281 i. 3829 j. 81973
8. Increase the following numbers by 25%:
a. 30 b. 60 c. 90 d. 1920 e. 3820
9. Decrease the following numbers by 25%:
f. 382 g. 827 h. 281 i. 3829 j. 81973



MONEY PROBLEMS

1.

Here is a CD rack.

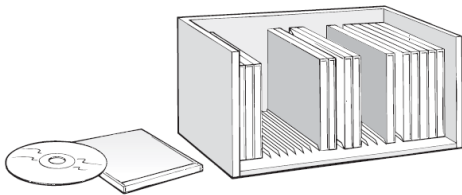

One rack holds **25** CDs.

David has **83** CDs.

2.



boots
£45.50



sandals
£12.75



trainers
£34.99

3.

Forest School sells badges for charity.



For each badge sold, **£1.20** is given to a charity.

a. If the CD cost £7.99 each, how much had David spent on CDs?

b. How many CD racks does David need to hold all his CDs?

c. If CD racks cost £12.76 each, how much change would David get from handing over 3 twenty pound notes?

d. If CDs rose in price to £12.95 each, how much more money would David need to spend on CDs to fill the racks he bought to hold them?

e. Assuming David bought the remaining CDs at the higher price of £12.76, how much has he spent altogether on CDs and CD racks?

a. How much change would a walker get from two £20 notes and a £10 note if they were buying a pair of boots?

b. Tom wants a pair of boots and a pair of trainers. How much change does he get from £100?

c. Instead of buying a pair of boots, Emily decided to buy a pair of sandals. How much money did she save herself?

d. Each of the items is advertised at a 20% reduction in the sale. How much does each item now cost?

a. It costs 14p to make each badge. For how much must Forest School sell each badge?

b. The school handed over £36 to charity. How many badges had they sold?

c. How much did it cost to make the badges they sold in part b?

d. The school want to raise £100 for the charity. The sell badges on one store and sell cakes on another. Each cake raises £0.48 for the charity. The school sell 51 cakes and 67 badges. How much more money do they need to raise?



DISTANCE PROBLEMS

Look at the diagrams below. Can you calculate the lengths asked for?

1

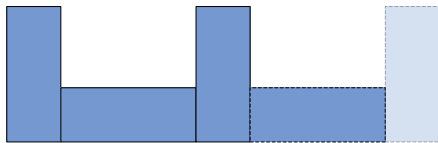
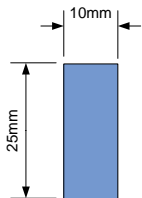

- This pattern is continued for 100 blocks. How long is the overall structure of the blocks?
- How many blocks would be needed if the overall structure was 120m long?

2

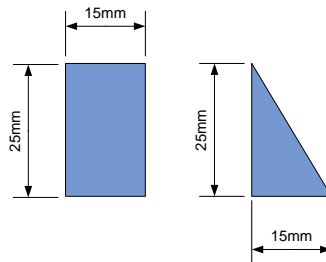
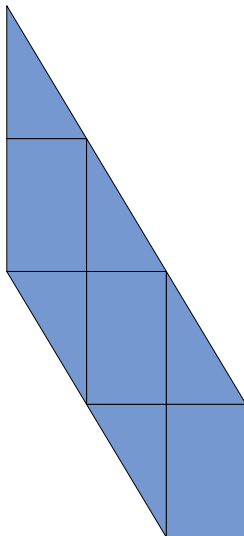

- If there are 60 rectangular blocks in the pattern, how many triangles would be needed?
- What sized rectangular room would be needed to house a structure with 75 rectangular blocks if they are arranged with the appropriate number of triangular blocks as shown opposite?

- A car travels at 60 mph for thirty minutes. How far does it travel?
- The same car travels at 30mph for an hour. How far does it travel?
- A truck travels at 45mph for six hours. How far does it travel?
- A tractor travels at 15mph for three hours and thirty minutes. How far does it travel?
- A motorbike travels at 70mph for four and a half hours. How far does it travel?
- A dustbin wagon travels an average of 12mph for five hours. How far does it travel?



PATTERNS

1

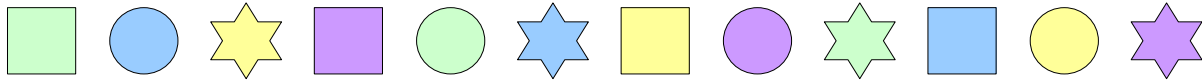

In the pattern above, there are three shapes and four colours. The pattern keeps repeating itself over and over again. For the following items in the pattern, give the colour and the shape. The colours are green, blue, yellow and lavender. The shapes are square, circle, star.

What is the colour and shape at the following positions in the pattern?

- a 6th b 3rd c 12th d 30th e 45th f 37th
- g 100th h 180th i 382nd j 1938th k 4829th l 18271st

2

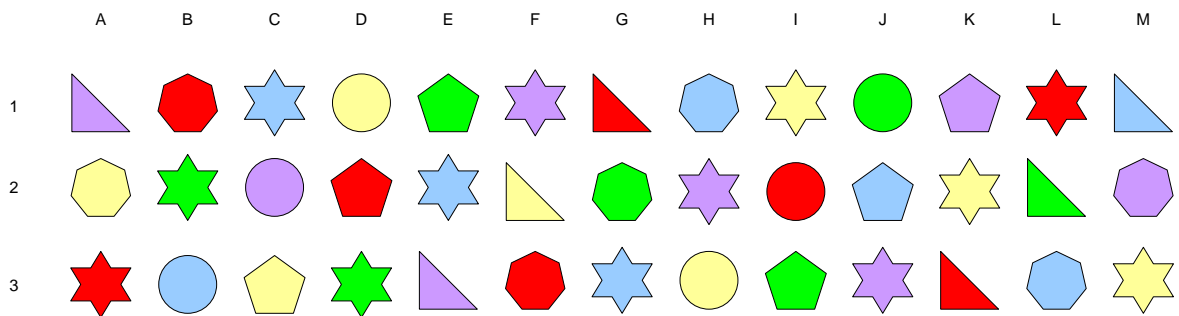

A slightly more complicated pattern is shown above marked on a grid. The grid consists of 13 columns and the first three rows of the grid are shown, although the grid goes on to have an infinite number of rows. The pattern starts at A1, B1, C1,..., M1, A2, B2, ...

For each answer, you need to give the colour and the shape, eg purple star, or the location eg G7.

- i. What shapes can be found in the following locations?
 - a. D1 b. B2 c. J2 d. L3 e. G3
- ii. What shapes would be found in the following locations if the pattern continued?
 - a. C4 b. J4 c. D5 d. L6 e. M9
- iii. Give the locations of the first twenty stars.
- iv. Give the locations of the first six yellow pentagons.
- v. Give the locations of the first six green heptagons.



AREA AND VOLUME

1. What is the area of the shape below:

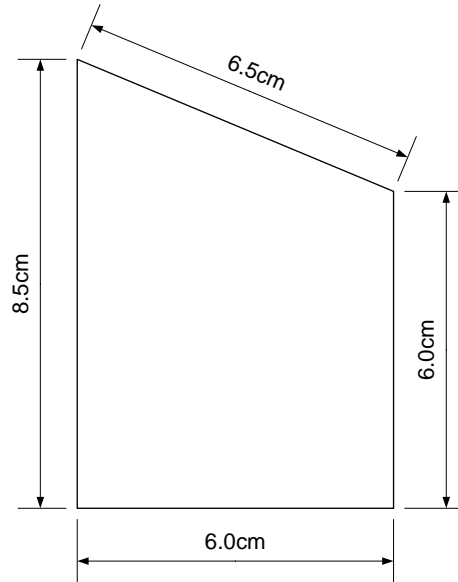

2. What is the difference in area between the two shapes below:

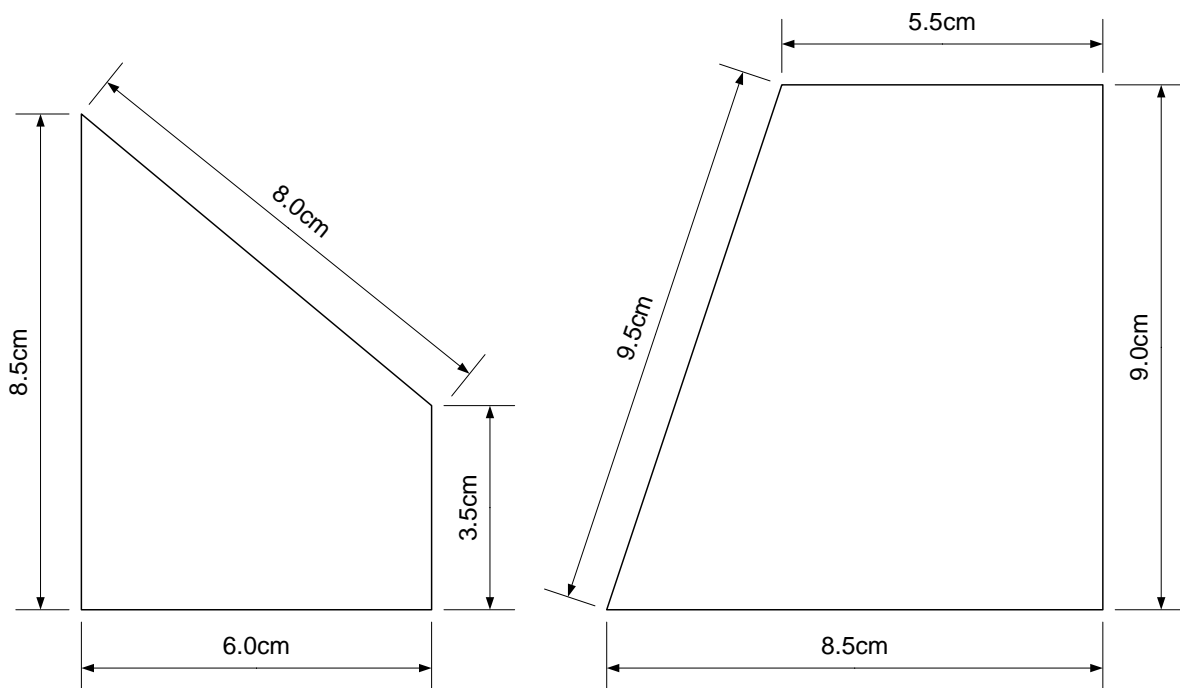



3. For the following cuboid, work out the:
- length of the edges;
 - surface area;
 - volume.

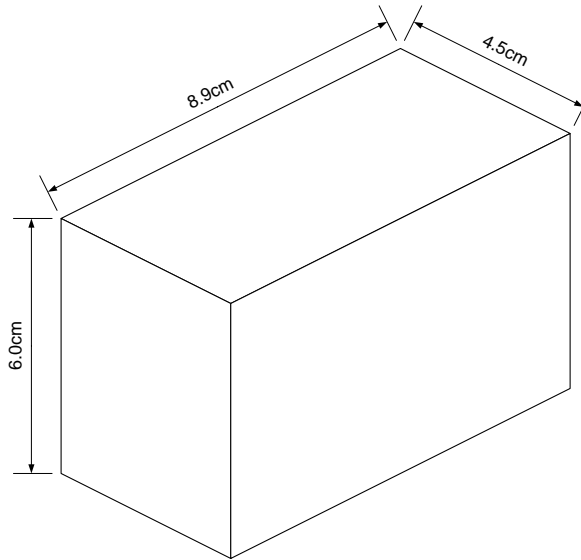

4. For the following prism, calculate the:
- length of the edges;
 - surface area;
 - volume.

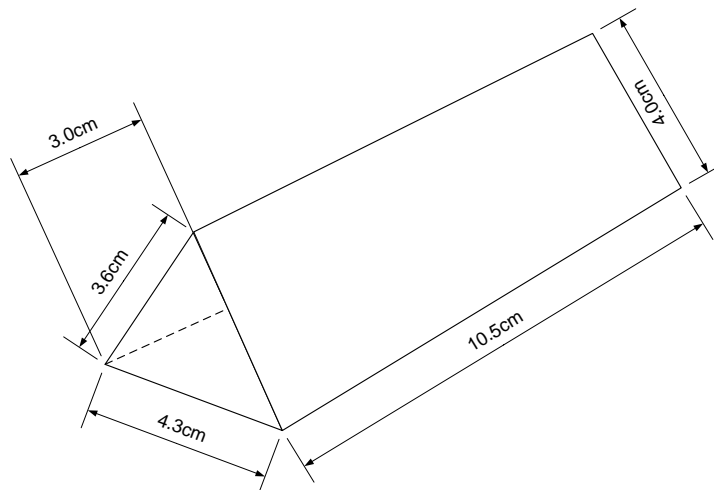

The dotted line shows the perpendicular height of the prism when using the 4cm side as the base. Assume each side of the prism to be a rectangle.



5. What is the area of the green shapes below?

a

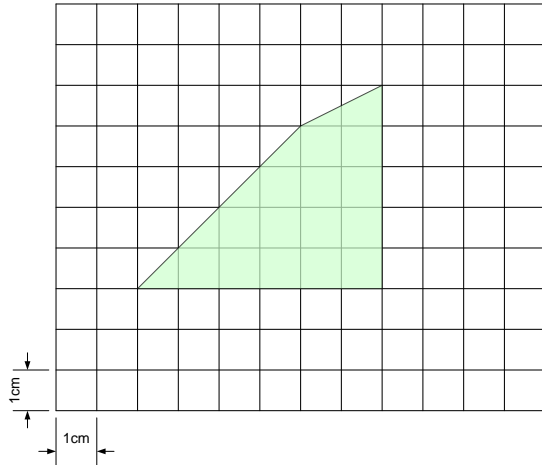

b

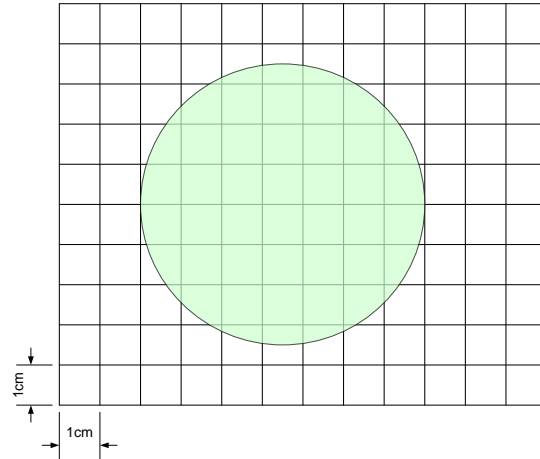

c

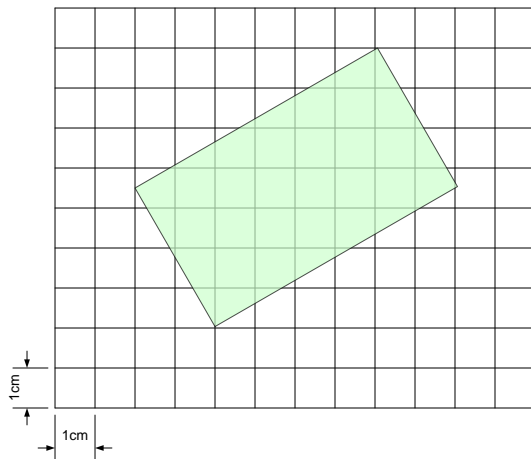

d

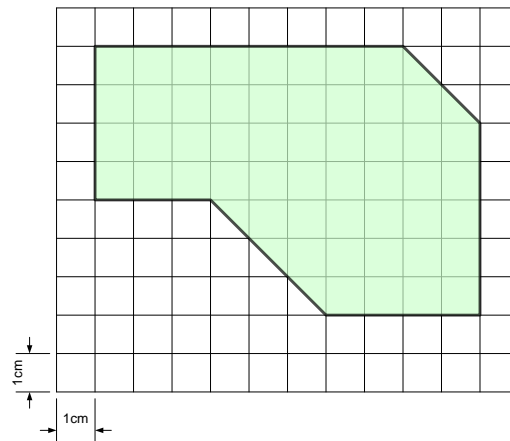

6. A block of wood is made where all the angles are right angles. The sides are 5cm, 4cm and 5cm long. From the block of wood, there is a cuboid shaped cut which has sides of 2cm by 3cm and a depth of 1cm. What is the volume of the block?

7. A piece of wood is cut in the shape of a triangular prism where the triangle is a right-angled triangle. The height of the triangle is 12cm and the base of the triangle is 5cm. The hypotenuse side of the triangle is 13cm long. The depth of the prism is 15cm.

a. What is the surface area of the prism?

b. What is the volume of the prism?



ALGEBRA

Copy out the questions below putting the correct answers into the boxes.

a

$$55 + \boxed{} = 120$$

$$600 \times 4 = \boxed{}$$

b

$$50 \div \boxed{} = 2.5$$

c

$$\boxed{} + 85 = 200$$

$$4 \times \boxed{} = 120$$

$$120 - 51 = \boxed{}$$

d

×	5	<input type="text"/>	<input type="text"/>
4	20	36	32
<input type="text"/>	35	63	56
<input type="text"/>	30	54	48

e

$$\boxed{} + 75 = 90$$

$$4 \times \boxed{} = 200$$

f How much does each parcel weigh?

Parcels A and B together weigh the same as parcel C.

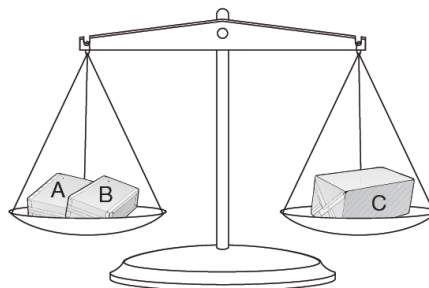

The three parcels weigh 800 grams altogether.

Parcel A weighs 250g.



NUMBER OPERATIONS WITH DECIMAL FRACTIONS

1	$40.302 \times 8.17 =$	16	$79.314 + 1.68 =$
2	$48.576 \times 7.24 =$	17	$3.171 - 4.52 =$
3	$64.192 \times 5.94 =$	18	$30.166 + 8.83 =$
4	$66.52 \times 6.89 =$	19	$82.962 - 5.27 =$
5	$68.332 \times 3.91 =$	20	$65.446 + 7.31 =$
6	$6.688 \times 2.87 =$	21	$49.917 - 5.72 =$
7	$19.089 \times 5.55 =$	22	$21.686 + 4.91 =$
8	$57.991 \times 3.98 =$	23	$4.55 - 1.7 =$
9	$77.593 \times 3.74 =$	24	$95.892 + 7.18 =$
10	$94.164 \times 2.78 =$	25	$95.591 - 6.29 =$
11	$81.051 \times 3 =$	26	$50.479 + 2.24 =$
12	$95 \times 4.78 =$	27	$21.195 - 5.65 =$
13	$82.383 \times 8.08 =$	28	$35.473 + 0.74 =$
14	$33.82 \times 3.3 =$	29	$87.703 - 9.01 =$
15	$74.928 \times 4.74 =$	30	$59.308 + 6.95 =$



RESOURCES TO CUT OUT AND STICK IN YOUR BOOKS

No 5 p 14

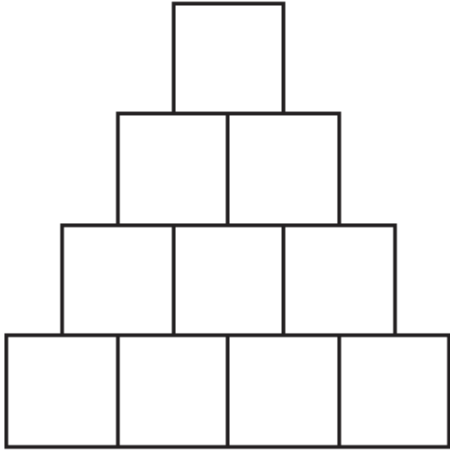

No 1 p 16

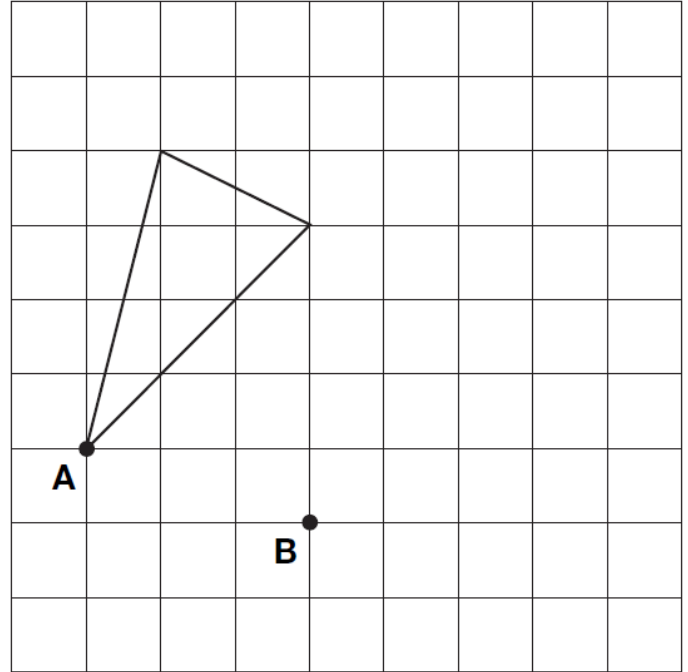

No 2 p 12

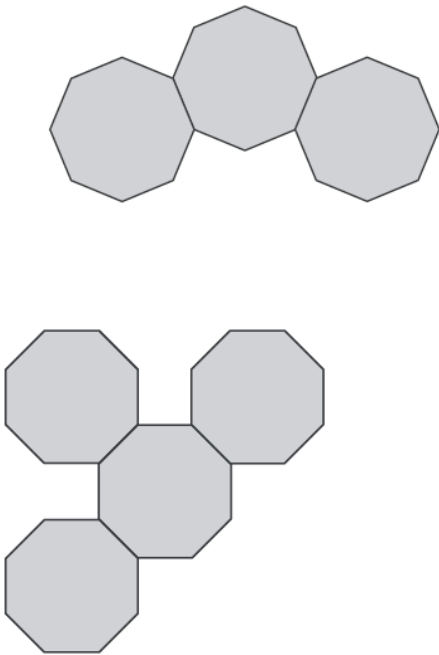

No 2 p 16

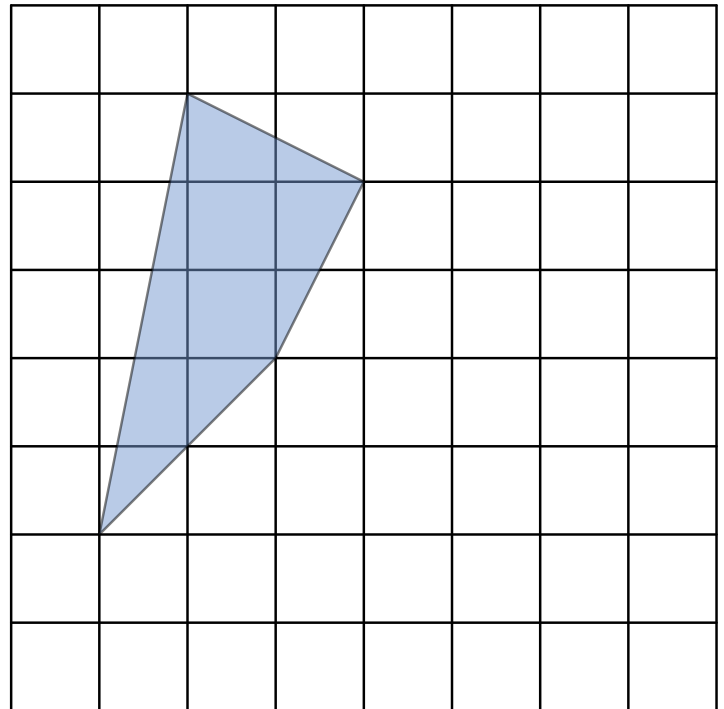



No 2 p 12

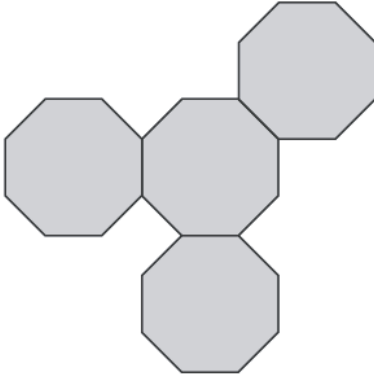

No 1 p 12

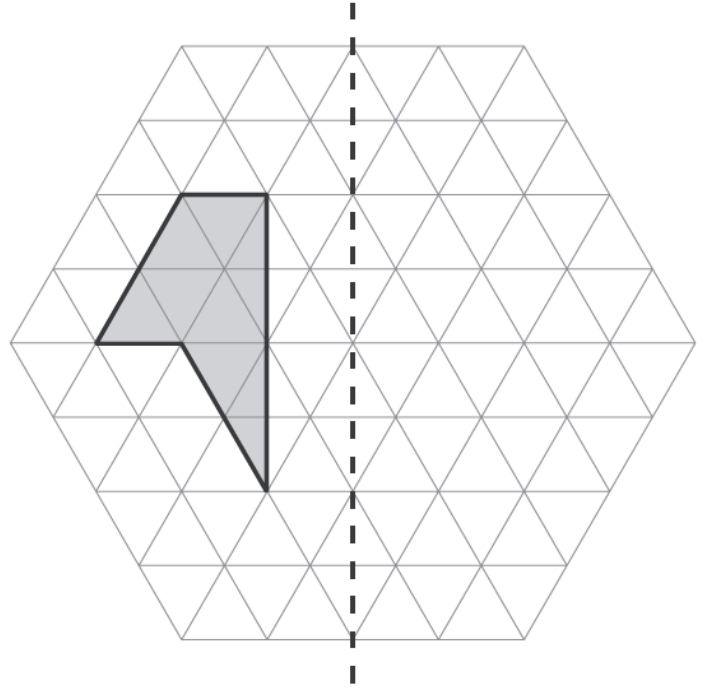

No 13 p 7

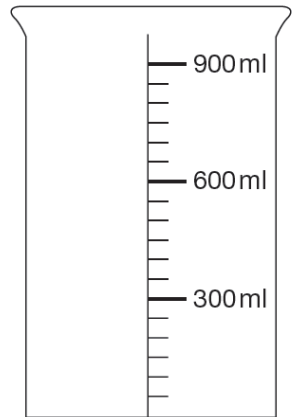
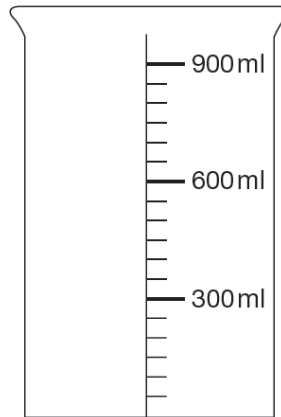
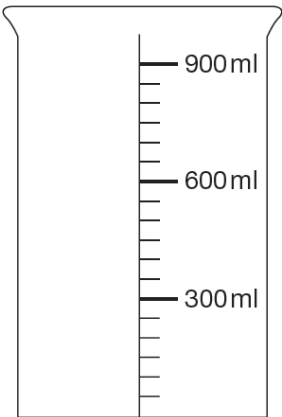

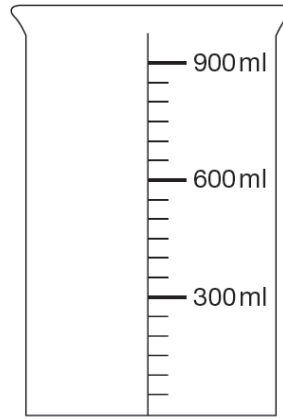
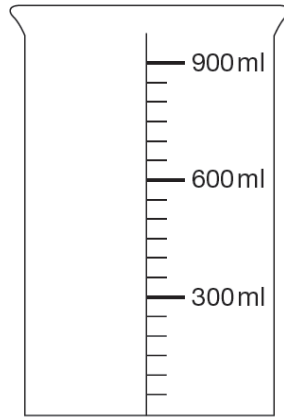
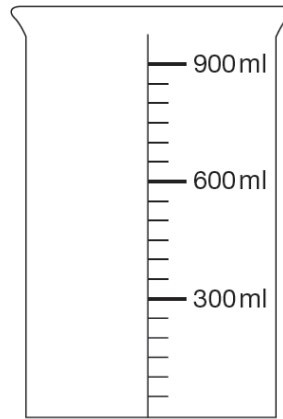
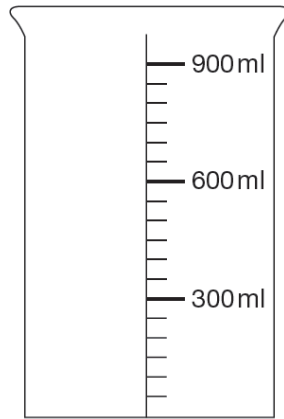
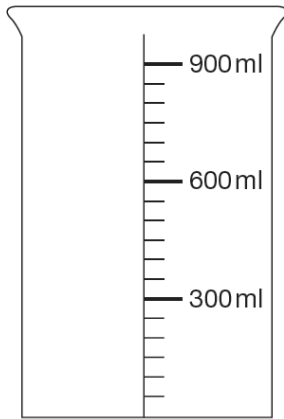
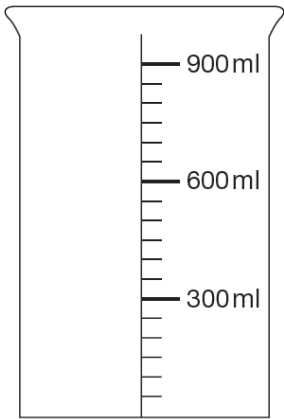

No 10 p 6

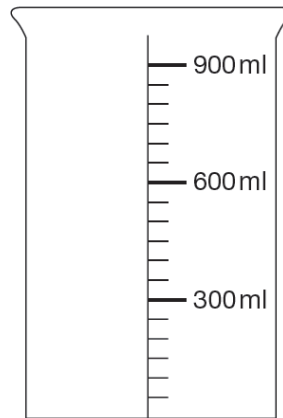
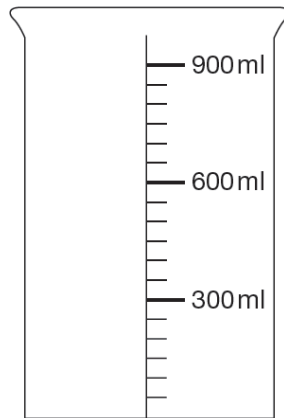
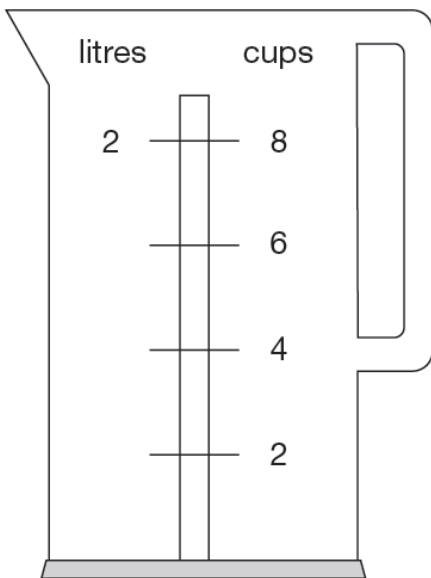

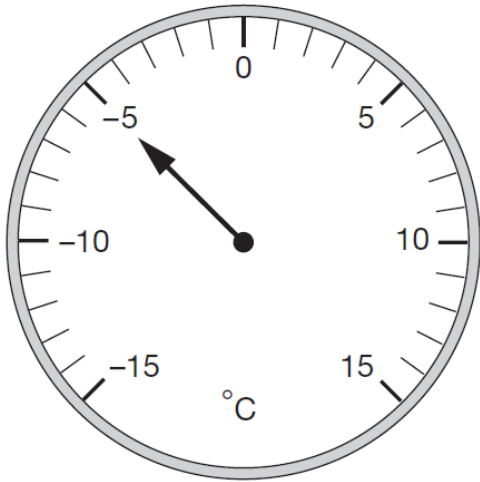

No 5 p 4

No 4 p 4

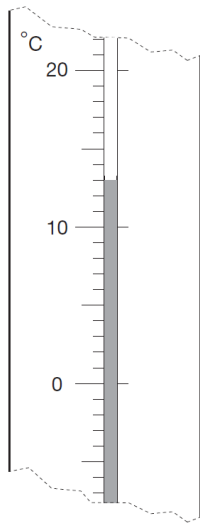

No 9 p 5

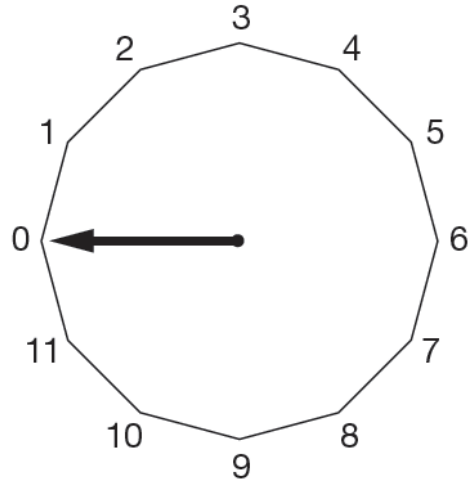

No 1 p 17

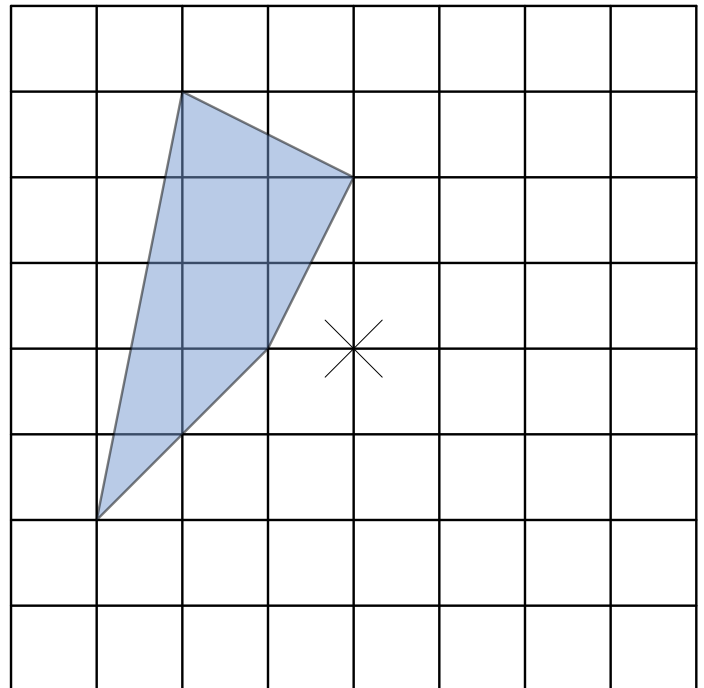



No 3 p12

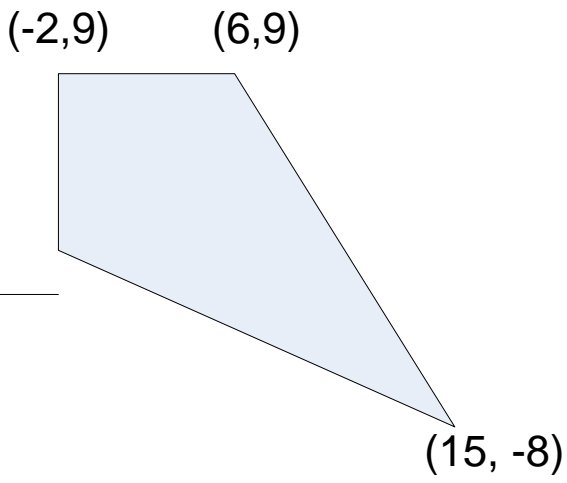

No 2 p 17

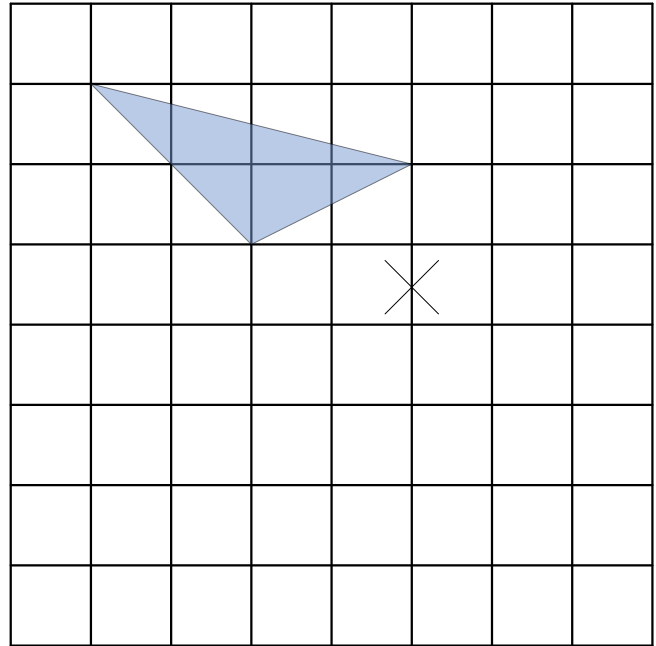

No 2 p 11

